



Series TRAKTOR /I

OPERATOR FOR SLIDING GATES UP TO 2200 KG



INSTALLATION AND USE MANUAL

TRAKTOR T/I
TRAKTOR M/I

Manual **6-1624970M** - rev. 1 - 11/01/2023
ENGLISH - Translated from the original language



INDEX

1. GENERAL WARNINGS FOR THE INSTALLER	3
1.1 - GENERAL ASPECTS OF SAFETY AND REGULATORY INCOMPATIBILITY	3
1.2 - SPECIFIC RISKS	3
1.3 - POTENTIAL DANGER POINTS FOR PERSONS	5
1.4 - GUIDELINES ON ELECTRICAL CONNECTIONS	6
1.5 - GUIDELINES FOR DOOR MOTORS	7
2. DESCRIPTION OF THE PRODUCT	8
2.1 - INTENDED USE	8
2.2 - TECHNICAL CHARACTERISTICS	9
2.3 - ANCHORAGE POINTS AND DIMENSIONS	10
2.4 - VIEW OF THE PRODUCT	11
2.5 - USE OF RELEASE LEVER FOR MANUAL MOVEMENT OF AUTOMATION	12
2.6 - TYPICAL INSTALLATION	13
3. INSTALLATION	14
3.1 - INSTALLATION OF THE FIXING PLATE	14
3.2 - INSTALLATION OF THE GEAR MOTOR	16
3.3 - FIXING OF THE RACK	16
3.4 - FIXING OF THE GEAR MOTOR	17
3.5 - DETERMINATION OF LIMIT POINTS	17
4. CT TRAKTOR INVERTER CONTROL UNIT	18
4.1 - VIEW OF THE ELECTRONIC BOARD	18
4.2 - MAIN POWER SUPPLY CONNECTION	19
4.3 - POWER SUPPLY CONNECTION ACCESSORIES	19
4.4 - ELECTRICAL CONNECTIONS OF CONTROL DEVICES	20
4.5 - ELECTRICAL CONNECTIONS OF SAFETY DEVICES	21
4.6 - ELECTRICAL CONNECTIONS OF SIGNALLING DEVICES	23
4.7 - CONNECTION OF ELECTRIC LOCK	23
4.8 - ANTENNA CONNECTION AND RADIO COMMUNICATION	24
4.9 - ELECTRICAL CONNECTIONS BY THE MANUFACTURER	24
5. PROGRAMMING	25
5.1 - FUNCTION OF THE PROGRAMMING KEYS	25
5.2 - DISPLAY MODE	26
5.3 - STANDARD VIEW	27
5.4 - SELECTION OF THE GATE CONFIGURATION	28
5.5 - LEARNING OF A REMOTE CONTROL	30
5.6 - LEARNING OF THE STROKES	32
5.7 - MENU OF BASIC FUNCTIONS	35
5.8 - MENU OF ADVANCED FUNCTIONS	38
6. ERROR MESSAGES	45
7. MAINTENANCE	46
8. PRODUCT DISPOSAL	46
9. WARRANTY	46
10. DECLARATION OF INCORPORATION	47

1. GENERAL WARNINGS FOR THE INSTALLER

1.1 - GENERAL ASPECTS OF SAFETY AND REGULATORY INCOMPATIBILITY

- Any use of this product other than permitted use /intended use is prohibited.
- The manufacturer shall not be liable for any damage caused as a result of improper use or as a result of installation not complying with the requirements of this manual.
- The product covered by this manual is configured in accordance with the Machinery Directive 2006/42/EC as a quasi-machine. It is therefore not in itself able to fully meet the regulatory reference requirements for the application for which it is intended.
- Regulatory compliance must be ensured at the level of the final installation (machine) to which the Machinery Directive 2006/42/EC fully applies and in which this product is incorporated.
- All operations indicated in this manual must be carried out exclusively by experienced, qualified and trained personnel.
- The preparation of the cables, the laying, the connection and the testing must be carried out observing the rule of art, in compliance with the rules, regulations and laws in force.
- During installation, testing and maintenance, the entire site shall be properly demarcated to prevent unauthorised persons, in particular minors and children, from entering.
- Before proceeding with the installation, check the mechanical goodness of the movable door and the guide and support structure.
- Before delivery to the user, check the compliance of the plant with the harmonised standards and the essential requirements in the Machinery Directive 2006/42/EC.
- Keep this manual in the technical file together with the manuals of the other devices used for the realization of the automation system.

1.2 - SPECIFIC RISKS

DANGER

RISK OF ELECTRIC SHOCK, EXPLOSION OR ELECTRIC ARC

- Shut down all equipment, including connected devices, before removing any lid or door, or before installing/uninstalling accessories, hardware, cables or wires, except for the conditions specified in the user manual for this equipment.
- To verify that the system is out of voltage, always use a correctly calibrated voltmeter at the rated value of the voltage.
- Before returning the live unit, reassemble and secure all covers, hardware and cables. Make sure that the cable inlet is sealed to prevent insect entry and moisture formation.
- Use this equipment and all products connected only to the specified voltage.
- If there is a risk of damage to personnel and/or equipment, use the necessary safety interlocks.
- Do not use this equipment for safety critical functions.
- Do not disassemble, repair or modify the equipment.
- This product is not suitable for installation in applications where it may come into contact with explosive or flammable atmosphere.

Failure to comply with these instructions will result in death or serious injury.



DANGER

RISK OF ELECTRIC SHOCK AND/OR FIRE

- Do not expose the equipment to liquid substances.
- Do not exceed the temperature and humidity ranges specified in the technical data and leave the slit area ventilated.
- Only use compatible accessories as indicated in the user manual.
- Use only cables of appropriate cross-section as indicated in the section "GUIDELINES FOR ELECTRICAL CONNECTIONS". Tighten the connections in accordance with the technical specifications for the tightening torques and verify the correct wiring.
- Electrical cables must not come into contact with parts that can heat up and with parts of the automation in motion.

Failure to comply with these instructions will result in death or serious injury.



DANGER

RISK OF IMPACT, CRUSHING, HOOKING AND ENTRAPMENT

- The door can be automated only if in good condition and if it complies with EN 12604.
- Take all appropriate precautions in accordance with EN 12453.
- Read the information in the section "GUIDELINES FOR DOOR MOTORS".

Failure to comply with these instructions will result in death or serious injury.



WARNING

RISK OF OVERHEATING AND/OR FIRE

- Do not use with loads other than those indicated in the technical data.
- Do not exceed the maximum current allowed; in case of higher loads use a contactor of suitable power.
- Power lines and output connections shall be suitably wired and fused when required by national and local regulatory requirements.

Failure to comply with these instructions may result in death, serious injury or damage to equipment.



WARNING

INCOMPATIBILITY OF LEGISLATION

- Ensure that all equipment used and systems designed comply with all applicable local, regional and national regulations and regulations.

Failure to comply with these instructions may result in death, serious injury or damage to equipment.



WARNING





- The reported data have been compiled and checked with the utmost care, however the manufacturer of the partly completed machine cannot assume any responsibility for any errors, omissions or approximations due to technical or graphic requirements.
- The automation manufacturer recalls that this manual does not replace what is required by the rules that the manufacturer of the motorized door/gate is required to comply with.

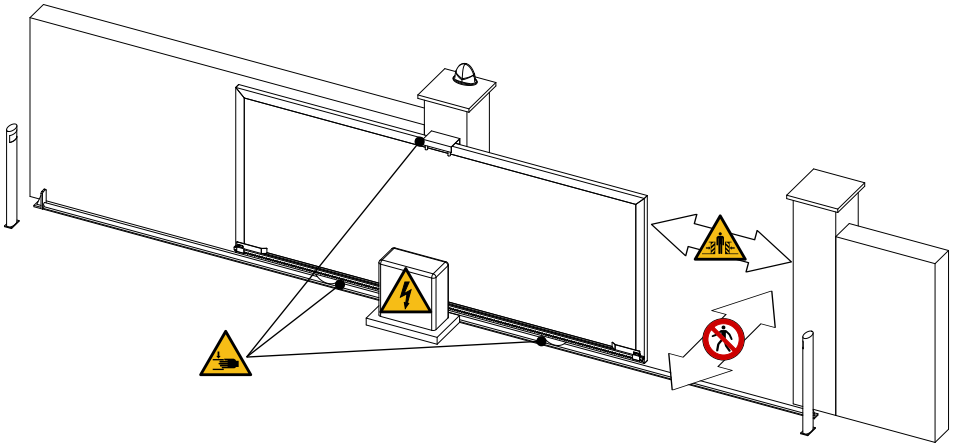

The manufacturer of this partly completed machine assumes no liability for any consequences arising from the use of this material.

1.3 - POTENTIAL DANGER POINTS FOR PERSONS



	<p>No transit allowed for pedestrians during movement</p>
	<p>Danger of electric shock</p>
	<p>Danger of crushing</p>
	<p>Danger of crushing hands</p>

1.4 - GUIDELINES ON ELECTRICAL CONNECTIONS

Prepare cable ducts on the installation site.

The tables for the connection of the various devices in a typical plant are listed in the table below and must be suitable for the type of installation, for example we recommend a cable type H07RN-F for outdoor installation.



CONNECTION	CABLE	LENGTH
Main power supply line	3 x 1,5 mm ² 3 x 2,5 mm ² 3 x 3,5 mm ²	Up to 10 m From 10 to 50 m Over 50 m
Flashing lamp	2 x 0,5 mm ²	Up to 20 m
Photocell - transmitter	2 x 0,5 mm ²	Up to 20 m
Photocell - receiver	4 x 0,5 mm ²	Up to 20 m
Key selector	4 x 0,5 mm ²	Up to 20 m

Only use the supplied connectors:

CLAMP POSITION	TYPE CLAMP
All	PHOENIX BCP-500-2GN

The following table shows the type and size of the allowable cables for the screw terminals of the above type and the tightening torques:

$\frac{\text{mm}}{\text{in.}}$ $\frac{6.5}{0.26}$								
mm ²	0.2 ... 2.5	0.2 ... 2.5	0.25 ... 2.5	2 x 0.2 ... 0.75	2 x 0.2 ... 0.75	2 x 0.25 ... 0.75	2 x 0.25 ... 0.75	2 x 0.5 ... 1.5
AWG	24 ... 14	24 ... 14	24 ... 14	24 ... 14	2 x 24 ... 18	2 x 24 ... 18	2 x 24 ... 18	2 x 20 ... 16

 Ø 3.5 mm (0.14 in.)		N • m	0.5
		lb-in	4.5

Use copper conductors (mandatory).

Avoid the presence of wires of exposed branches or coming out of the clamp.

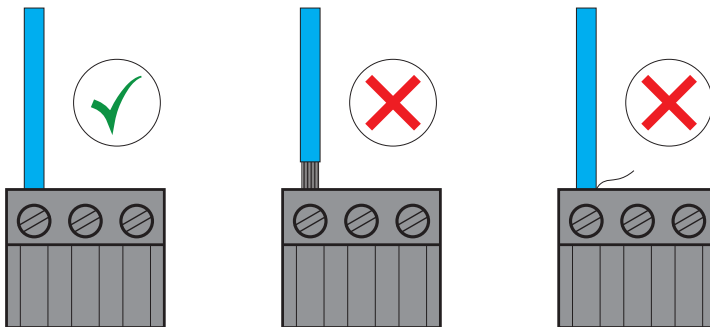

1.5 - GUIDELINES FOR DOOR MOTORS

The risk assessment must be carried out before installing the motor.

The following are some checks and precautions commonly applicable to the systems of motorized doors/ gates; you must therefore, depending on the different situations, consider any additional risks and exclude those not applicable in accordance with the principles of safety integration provided by the Machinery Directive.

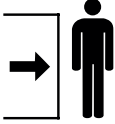
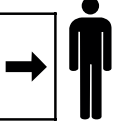
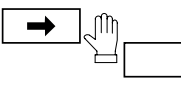
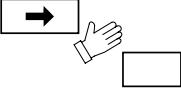
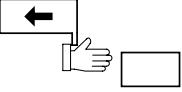
				
IMPACT	CRUSHING	SHEARING	CONVEYING	HOOKING

ANGER

- Verify that at each of the two extreme positions of the stroke there is a fixed mechanical stop that stops the gate in case of malfunction of the limit switches. For this purpose, the mechanical stop must be sized to withstand the static thrust of the engine plus the kinetic energy of the gate.
- The columns of the gate must have on top of the anti-derailment guides to avoid involuntary disengagement.
- Check that no entrapment points can be generated (for example between the open gate door and the wall).
- Check that the upper guides do not cause friction.
- Check that the gate is stable and that the sliding wheels are in good condition and greased.
- Check that the ground guide is well fixed to the ground, completely on the surface and free of irregularities that can hinder the movement of the gate.
- Check that the fastening point of the automation is in an area protected from impact and that the mounting surface is solid.
- Provide adequate pipes and conduits for the passage of electrical cables ensuring protection against mechanical damage.
- **Implement any other type of precaution and check as indicated by the rules in force.**
- **The method of control of the gate, as well as the accompanying safety devices, must conform to the intended use of the gate itself.**



MINIMUM LEVEL OF PROTECTION OF THE MAIN EDGE IN RELATION TO THE TYPE OF USE

TYPE OF DOOR ACTIVATION	TYPES OF USE		
	Trained users (Public not likely to be present)	Trained users (Public likely to be present)	Untrained users
Hold-to-run control mode of operation	A	B	Not possible
Impulse activation in sight of the door	C or E	C or E	C and D, or E
Impulse activation out of sight of the door	C or E	C and D, or E	C and D, or E
Automated control	C and D, or E	C and D, or E	C and D, or E

A. Hold-to-run control button.
 B. Hold-to-run control button equipped with key switch or similar.
 C. Limitation of forces or force limitation devices.
 D. Additional devices to reduce the probability of contact with persons or obstacles.
 E. Presence detection protection devices installed so that a person cannot be touched by the moving door.

2. DESCRIPTION OF THE PRODUCT

Irreversible operator complete with electronic board CT TRAKTOR INVERTER and electro-mechanical limit switch, for sliding gates with a maximum weight of 2200 kg. Drive electric motor with inverter technology for precise movement management. It has inputs for connection to control and safety devices, and outputs for management of a flashing light and courtesy light. Radio receiver integrated in the board for control by 433.92 MHz remote controls.

2.1 - INTENDED USE

Actuator for sliding gates weighing not more than 2200 kg, placed on driveways for condominium or industrial use.

DANGER

Any installation or use other than as indicated in the following manual is prohibited.



2.2 - TECHNICAL CHARACTERISTICS

Commercial name		TRAKTOR T/I	TRAKTOR M/I
The product complies with the following Directives and Harmonized Standards		2014/53/EU	
Construction of the device		Electronic control device to be incorporated.	
Purpose of the device		Operating control device (non-safety)	
Control unit		CT TRAKTOR INVERTER installed on board	
Software Class		A	
Power supply		230 Vac \pm 10% 50/60 Hz	
Radio transmission		Rolling Code 433,92 MHz	
Type of electric motor		3-phase Induction Motor	1-phase Induction Motor
Power consumption in standby mode	mA	50	
Maximum power consumption at startup	A	10	
Typical rolling current absorbed	A	2	3,5
Electric motor power	W	750	600
Maximum manoeuvring speed*	m / min	16	15
Maximum thrust	N	4700	3000
Maximum torque on the pinion	Nm	180	115
Maximum weight of movable part*	kg	2200	
Service factor	%	80	
Maximum continuous duration	min	8	
Weight of the gear motor	kg	9	
Pinion module		M4 Z19	
Insulation class		I	
Degree of pollution		2	
Acoustic pressure	dB	\leq 70	
Environmental operating conditions		TA: -20...+55 °C RH max 90% without condensation	
Conditions of transport and storage		TA: -40...+70 °C RH max 90% without condensation	
Degree of environmental protection		IPx4	
Thermally protected motor		YES	
Emergency release		Release lever with key	

NOTE

• The above values refer to a standard installation as follows: gate length 8 meters, with a total weight of 2200 kg uniformly distributed, installed according to the rule of art, free of mechanical conflicts and/ or accidental friction, with four wheels for sliding of 200 mm diameter and moving along a rail installed in the plane.

The values were measured at an ambient temperature of about 20 °C.

• * Value referred to the gear motor in its factory configuration. See section "SELECTING THE GATE CONFIGURATION" for the values of the different configurations.



2.3 - ANCHORAGE POINTS AND DIMENSIONS

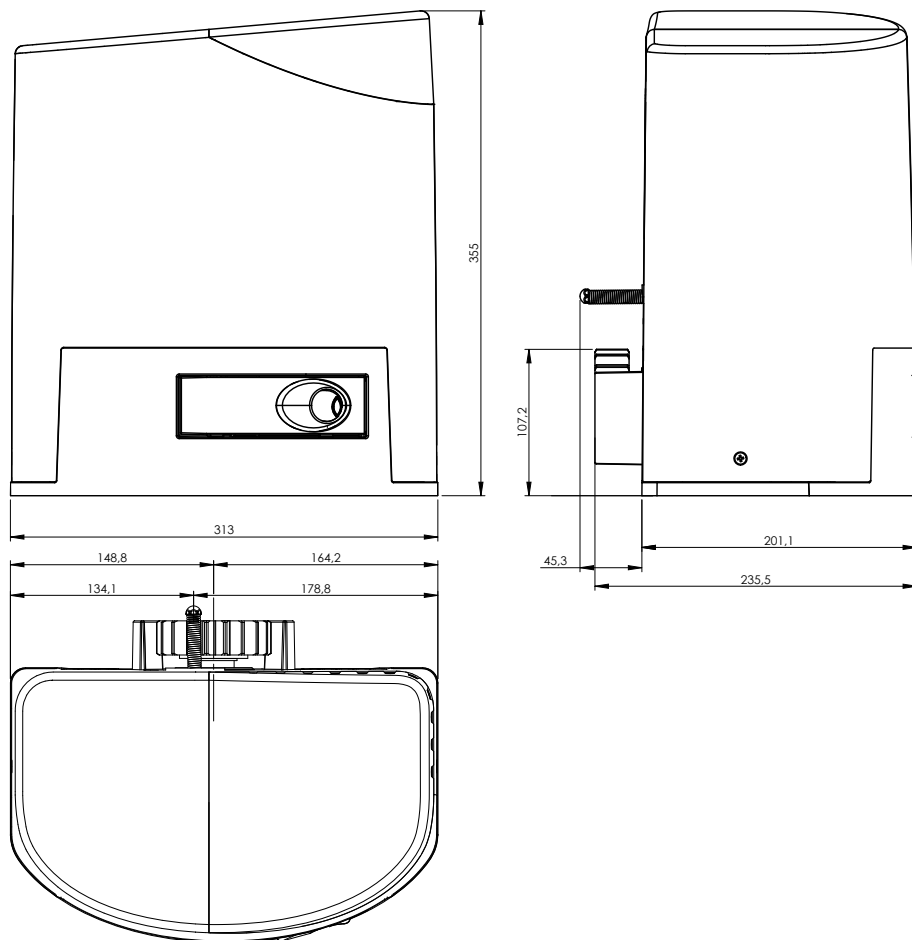

FIXING PLATE

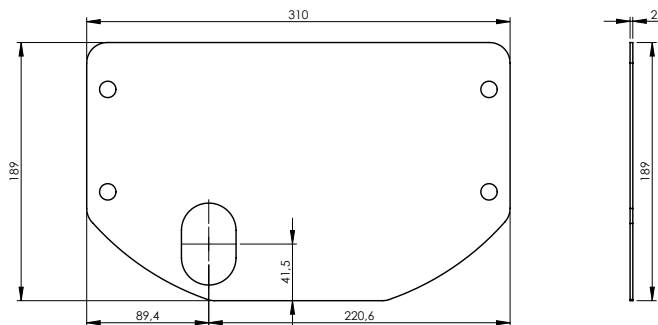

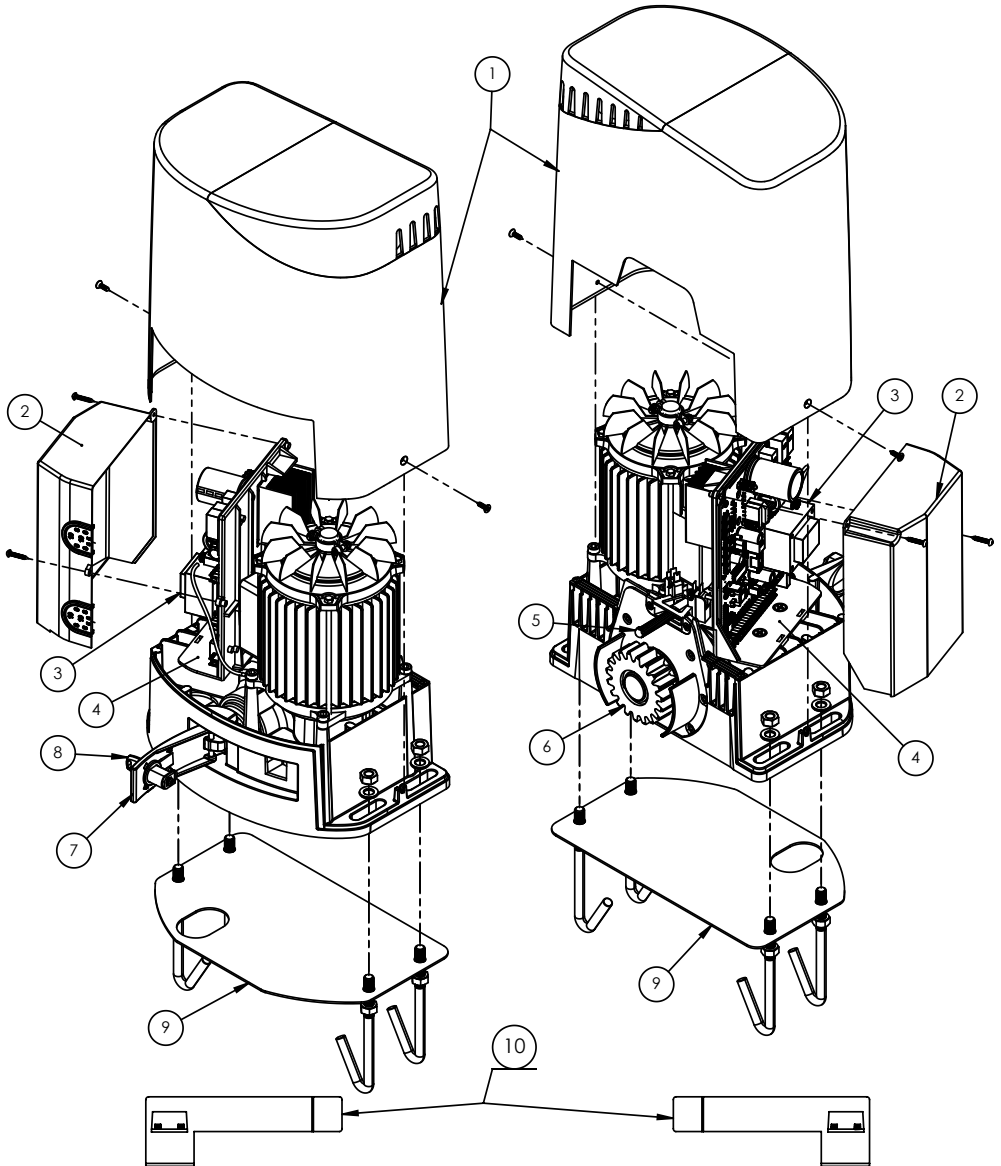

Description:

1. External cover
2. Protective cover of the board
3. Electronic board
4. Plastic support for board
5. Electro-mechanical limit switch

6. Pinion
7. Release lever
8. Unlock key
9. Fixing plate complete with anchors
10. Brackets for mechanical limit switch

RELEASE OF MOTOR TRANSMISSION

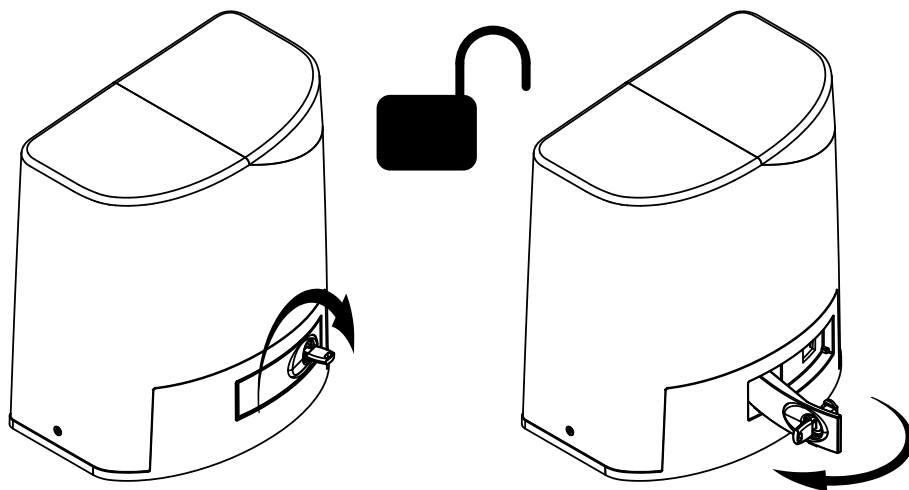

MOTOR TRANSMISSION INSERTION

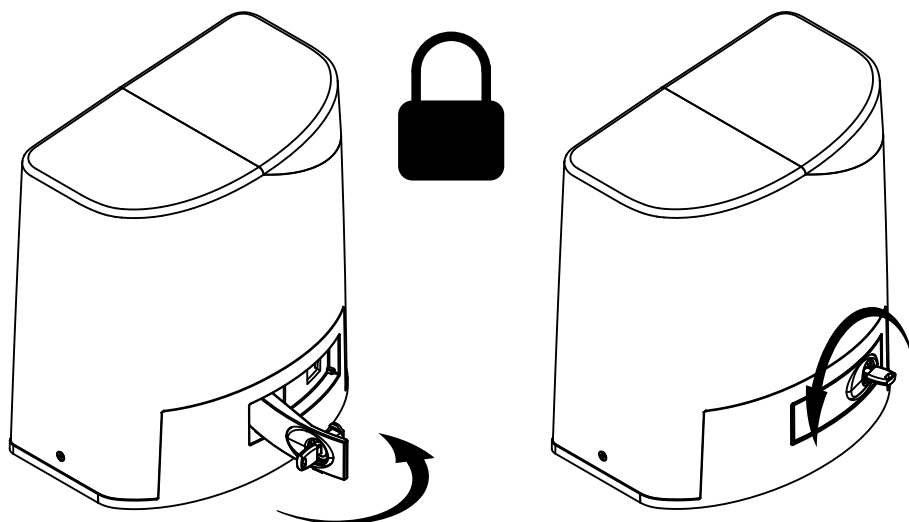

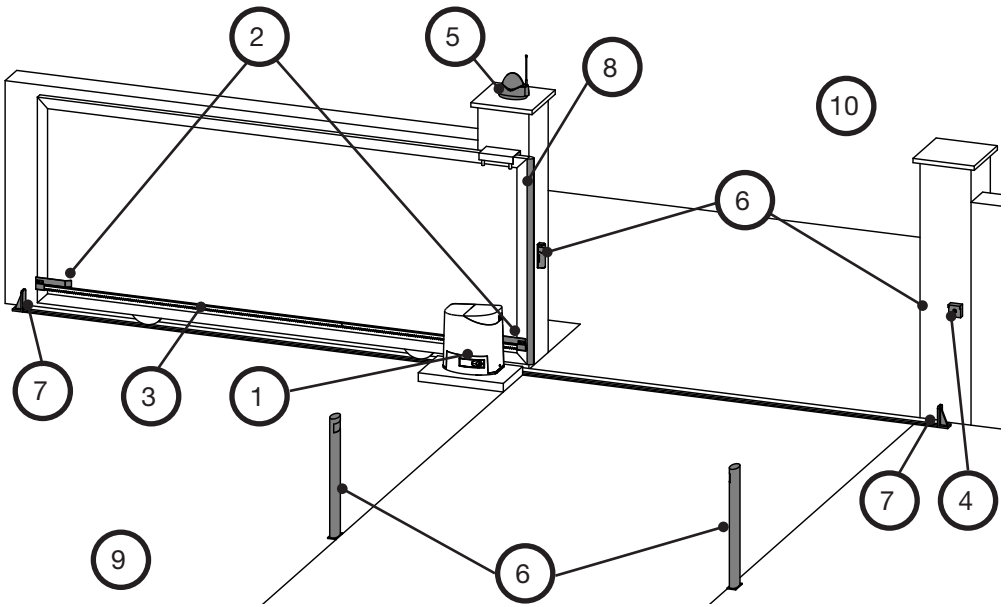

Description:

- | | |
|--------------------------------|--------------------------|
| 1. TRAKTOR | 6. Photocells |
| 2. Limit switch bracket | 7. Mechanical limit stop |
| 3. Rack | 8. Safety edge |
| 4. Key switch | 9. Internal area |
| 5. Flashing light with antenna | 10. External area |

3. INSTALLATION

NOTE

The following illustrations are just examples, as the space for fixing the automation and accessories varies depending on the dimensions. It is therefore up to the installer to choose the most suitable solution. The drawings refer to the automation installed to the left of the passage.



3.1 - INSTALLATION OF THE FIXING PLATE

NOTE

- The number of tubes depends on the type of system and the number and type of accessories provided.
- The pipes must pass through the prepared fixing plate holes.
- The fixing plate, once positioned, must be perfectly level and with the thread of the screws perfectly on the surface.



Make the excavation to contain a counter frame for the realization of the foundation of such dimensions as to support the weight of the automation.

The surface of the foundation should be larger than the fixing plate.

See image (recommended minimum size).

Prepare the corrugated pipes required for connections from the junction well.

Insert the counter frame into the excavation.

The frame shall be 50 mm above ground level.

Insert an iron grid into the counter frame to reinforce the concrete.

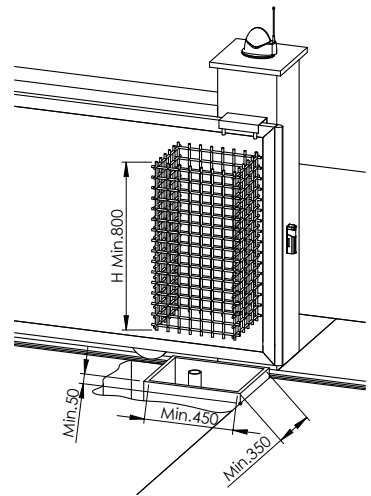

Assemble the hooks to the fixing plate using, at the bottom only the nut, and at the top a washer and a nut.

The part under the plate will be completely covered with cement.

The washer and the nut placed above the plate will serve subsequently to fix the gear motor to the plate itself.

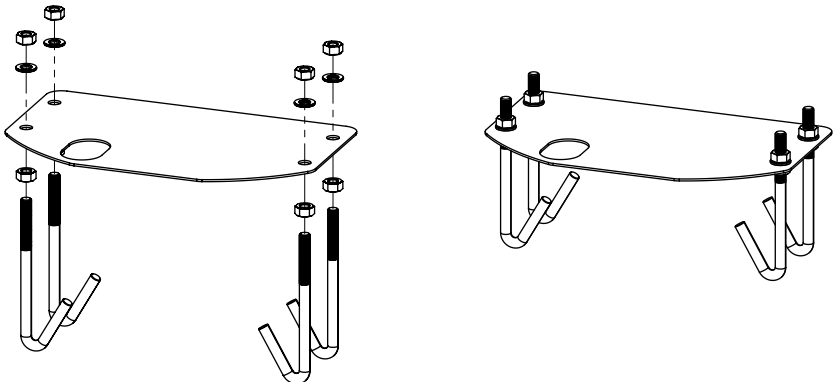

Place the fixing plate respecting the measurements in the drawing to ensure the correct transmission of the movement on the rack.
Fill the concrete frame making sure that the plate remains on the surface.
Allow the cement to solidify for at least 24 hours.

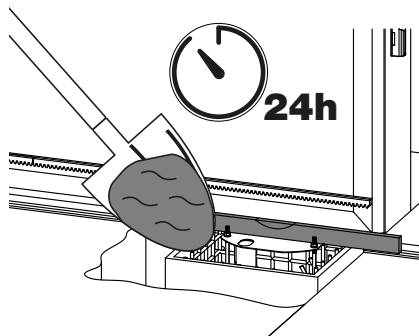
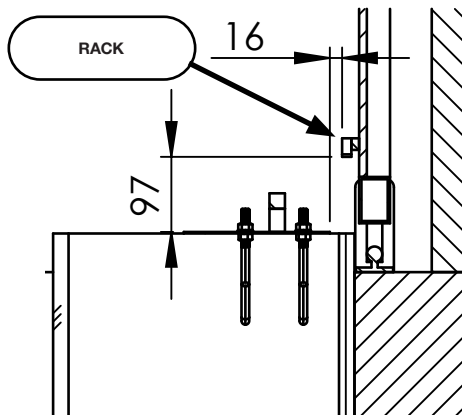

Remove the counter frame.
Fill the soil around the concrete block.
Remove the washers and nuts above the fixing plate.
Insert the electrical cables into the pipes until they exit at least 500 mm.

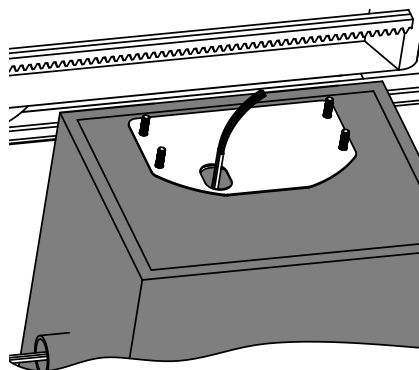
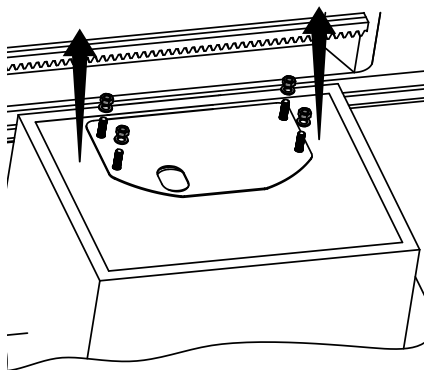

3.2 - INSTALLATION OF THE GEAR MOTOR

NOTE

- *The electrical cables must pass through the appropriate hole at the bottom of the motor body.*



Remove the screws, remove the outer cover and unlock the motor transmission.
Place the gear motor, aligning it, above the fixing plate.
The threaded part of the hooks must pass through the slots of the gear motor body.

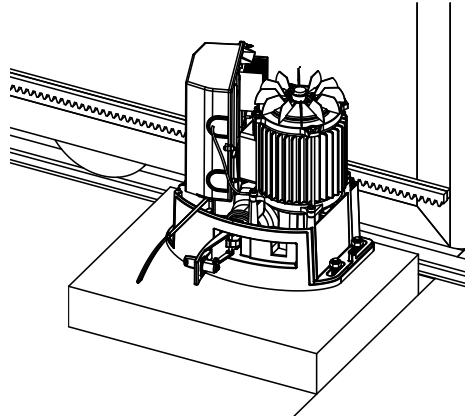
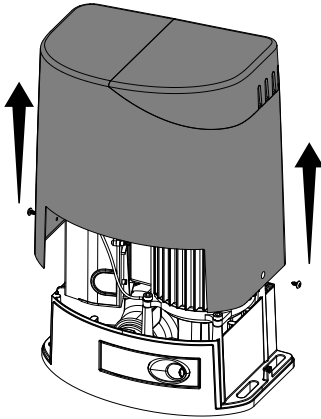

3.3 - FIXING OF THE RACK

NOTE

- *The weight of the gate should not burden the automation.*
- *The pinion must be centered on the rack width.*



Place a piece of rack over the pinion and fix it to the gate, taking care that the rack is level and has a constant distance from the pinion of 1-2 mm.

Attach the rack to the gate in its entire length.

To assemble the rack modules, use a scrap piece by placing it under the joint point and locking it with two clamps.

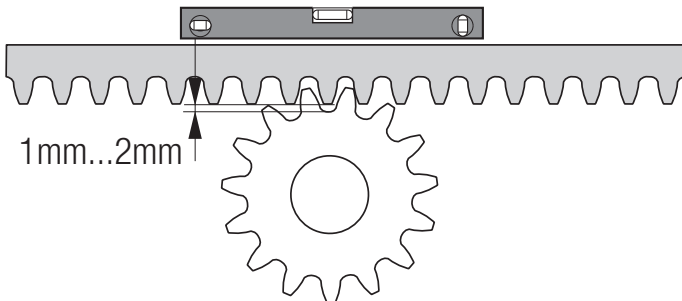

3.4 - FIXING OF THE GEAR MOTOR

Proceed to fixing only after adjusting and checking the pinion-rack coupling for the entire length of the gate.
Secure the automation firmly to the mounting plate using the supplied washers and nuts.
Make some manual movements to open and close the gate completely to verify that there are no anomalies.

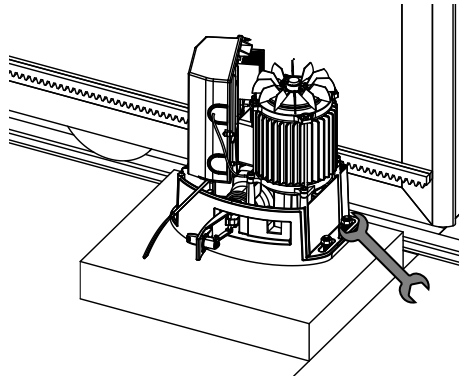

3.5 - DETERMINATION OF LIMIT POINTS

NOTE

- *The gate must not press on fixed mechanical stops.*



Manually bring the gate to the OPEN GATE position, at least 20 mm away from the mechanical stop.
Slide the opening end bracket onto the rack.
The spring must trigger the electro-mechanical limit switch.
Fix the opening limit switch bracket with the headless screws (supplied).

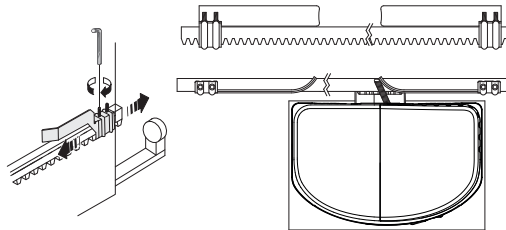

Manually bring the gate to the CLOSED GATE position, at least 20 mm away from the mechanical stop.
Slide the closing end bracket onto the rack.
The spring must trigger the electro-mechanical limit switch.
Fix the closing limit switch bracket with the headless screws (supplied).

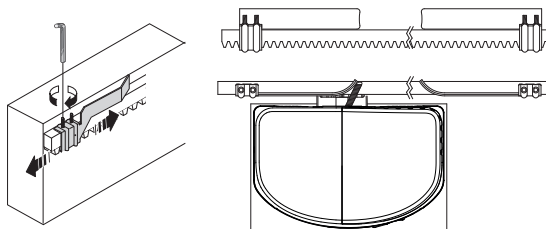

4. CT TRAKTOR INVERTER CONTROL UNIT

After the mechanical installation proceed with the connection of the cables to the control board.

4.1 - VIEW OF THE ELECTRONIC BOARD

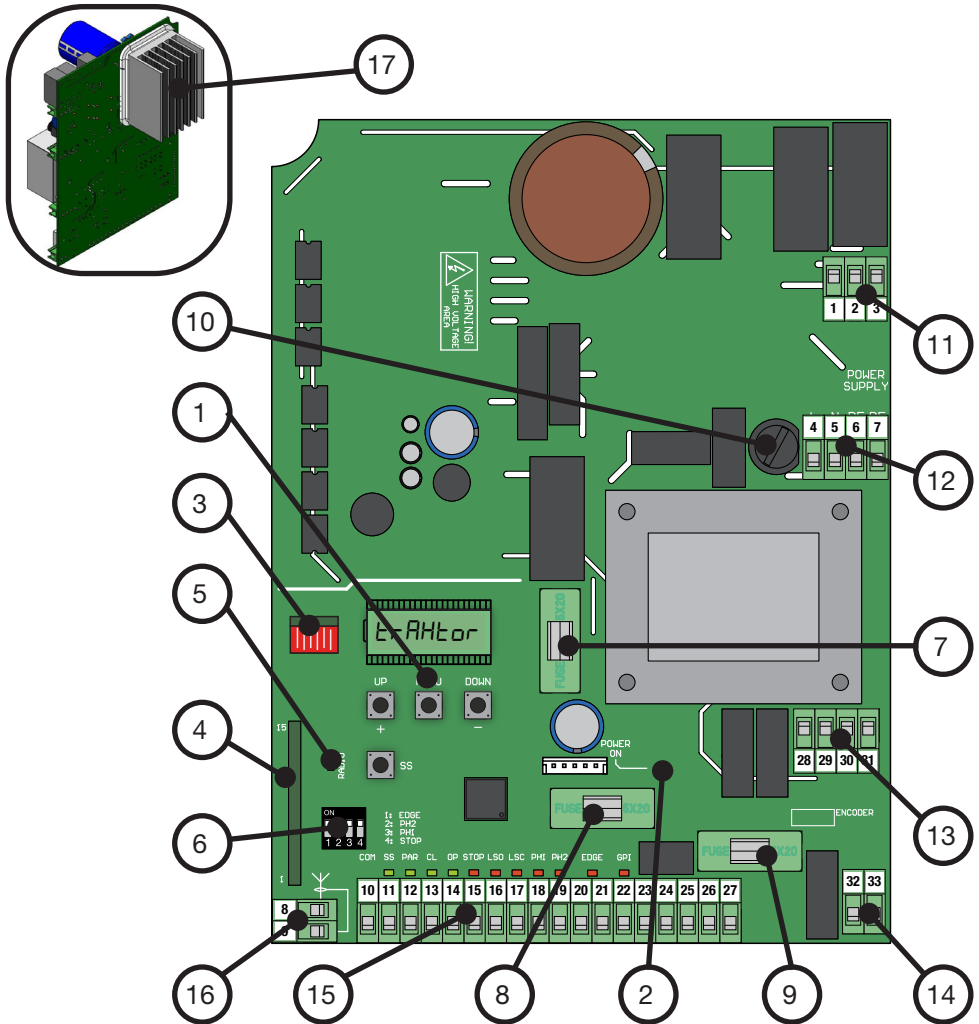

- | | |
|--|---|
| 1. Display and buttons | 10. FUSE4 - Line and motor protection (T 10 A) |
| 2. Led POWER ON | 11. Terminal for connecting the motor |
| 3. Radio Memory | 12. Terminal for connecting the main power supply |
| 4. Radio Module | 13. Terminal for connection of signalling devices |
| 5. Led Radio | 14. Terminal for electrical lock connection |
| 6. Dip-switch | 15. Terminal for connection of accessories |
| 7. FUSE1 - Protection of wired inputs (F 250 mA) | 16. Terminal for antenna connection |
| 8. FUSE2 - Protection 24 Vac (F 250 mA) | 17. Heat sink |
| 9. FUSE3 - Protection 24 Vdc (F 250 mA) | |

4.2 - MAIN POWER SUPPLY CONNECTION

# TERMINAL	FUNCTION	RATING
4	L - Phase cable	Connect power from network distribution 230 Vac ± 10% 50/60 Hz
5	N - Neutral cable	
6	PE - Earthing cable	
7	Reserved for connection performed by the manufacturer	

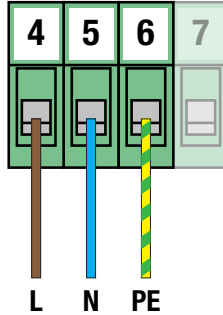

4.3 - POWER SUPPLY CONNECTION ACCESSORIES

# TERMINAL	FUNCTION	RATING
24 - 25	Power output 24 Vdc	250 mA MAX
26 - 27	Power output 24 Vac	250 mA MAX

Terminal 23 is reserved for the use of the function of TEST PHOTOCELLS and SAFETY EDGE TEST. Refer to advanced parameters for configuration and connections.

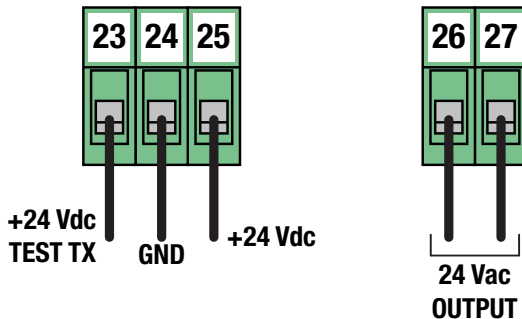

# TERMINAL	FUNCTION	RATING
10	COMMON CONTACT	Connect a clean contact (voltage free) Normally Open. Signal LED Normally OFF.
11	STEP-BY-STEP	
12	PARTIAL OPENING	
13	CLOSE	
14	OPEN	

Step-by-step function

At each activation it performs sequentially OPEN-STOP-CLOSE-STOP. You can configure the execution mode using the basic parameter.

Partial Opening function

Performs a partial opening of the automation. The width of the opening can be configured using the basic parameter.

Close function

Performs a complete closing. If kept active, keep the gate in the "CLOSED GATE" position and ignore any other commands.

Open function

Performs a full opening. If kept active, keep the gate in the "GATE OPEN" position and ignore any other commands.

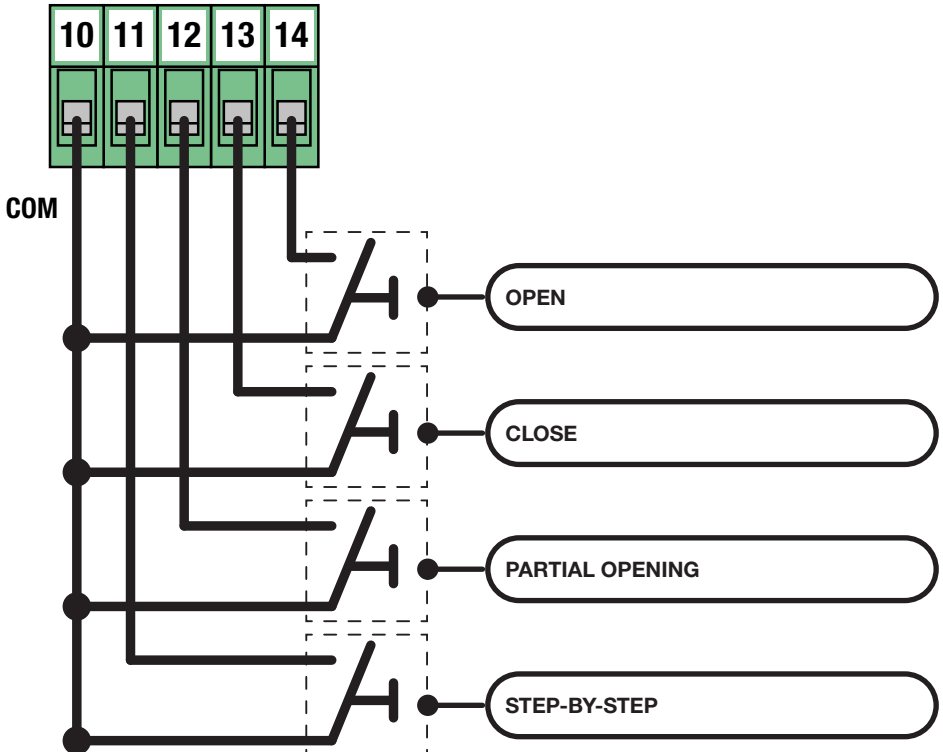

NOTE

If *EDGE*, *PH2*, *PH1* and *STOP* contacts are not used, they must be disabled using the *DIP-SWITCH*.
 This operation is possible by placing the corresponding selector in the *ON* position.



# TERMINAL	FUNCTION	RATING
10	COMMON CONTACT	
15	STOP	Connect a clean contact (voltage free) Normally Closed. Signal LED Normally On.
18	PHOTOCELL INPUT PH1	
19	PHOTOCELL INPUT PH2	

STOP button

When it intervenes it completely stops the automation and prevents any automated or user command.

Input PHOTOCELL PH1

During the closing movement, it stops the movement of the automation and performs a reversal until the gate reaches the OPEN GATE position.

Use the parameters to configure the behavior of the photocell input.

Input PHOTOCELL PH2

During the opening movement, temporarily stops the motion for as long as the photocell is engaged.

During this phase the flashing light cyclically performs 3 flashes.

Once restored the contact resumes movement in the direction of opening.

Use the parameters to configure the behavior of the photocell input.

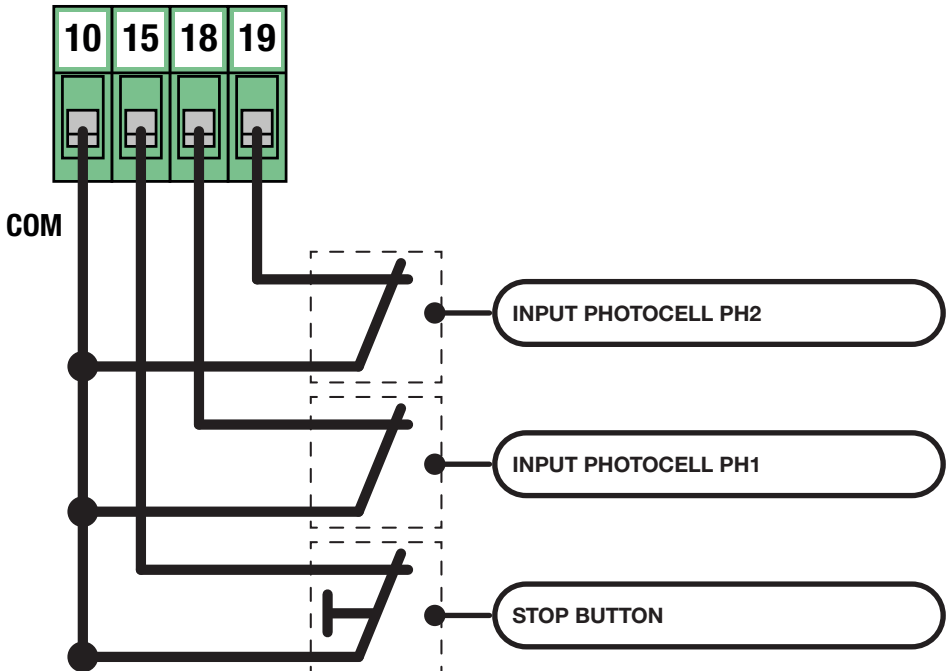

# TERMINAL	FUNCTION	RATING
20 - 21	SAFETY EDGE	Connect mechanical (NC) or resistive (8.2 Kohm) sensitive edges. Signal LED Normally On.

Input SENSITIVE EDGE

During the closing movement, it stops the movement of the automation and performs a reversal until the gate reaches the OPEN GATE position.

Use the parameters to configure the behavior of the sensitive edge input and the device type in use.

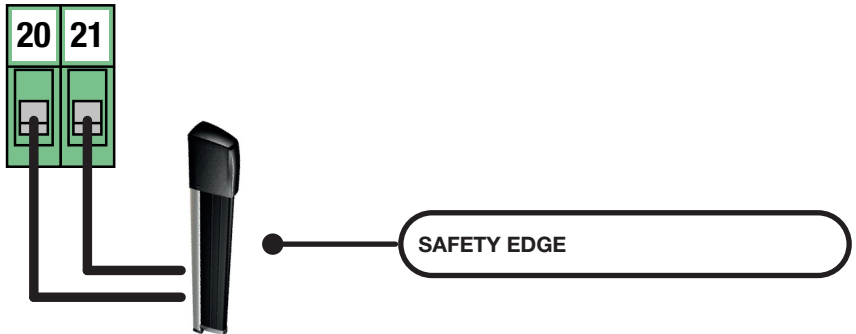

NOTE

Once you have finished the connections, before starting the programming, check that all the red lights of the safeties are on.

If this does not happen, verify that the un-connected inputs are disabled and that the connected devices are properly powered and working.



Photocell series FT / IRIS

Standard connections.

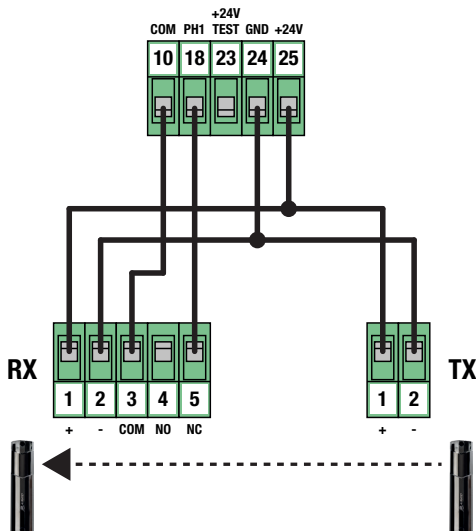

4.6 - ELECTRICAL CONNECTIONS OF SIGNALLING DEVICES

# TERMINAL	FUNCTION	RATING
28 - 29	Courtesy light	MAX 230 Vac 60 W
30 - 31	Flashing lamp	MAX 230 Vac 60 W

The outputs are active during the opening and closing phases of the automation.
Refer to the advanced parameters to configure the flashing mode and the lighting time of the courtesy light.

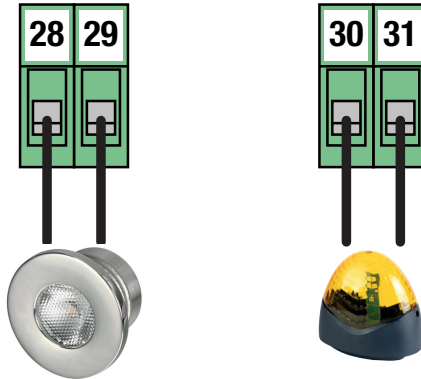

4.7 - CONNECTION OF ELECTRIC LOCK

# TERMINAL	FUNCTION	RATING
32 - 33	Electrical lock	Clean contact (voltage free).

Clean contact for connection of an electric lock.

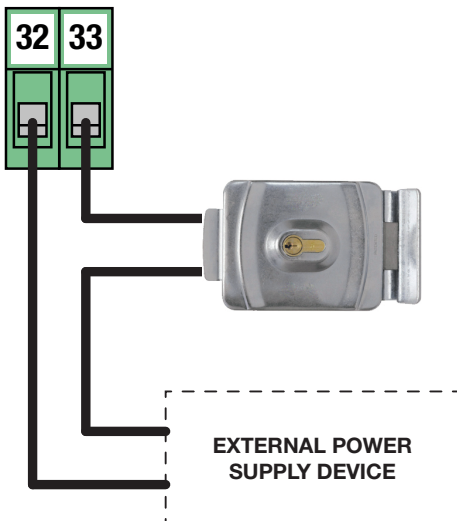

The control unit does not provide power for the electric lock, so it will be necessary to use an external power supply device compatible with the power required by the electric lock. Use the following connection scheme.



4.8 - ANTENNA CONNECTION AND RADIO COMMUNICATION

WARNING		
<ul style="list-style-type: none"> • Do not place the control unit inside metal containers. • The maximum range can vary significantly in the presence of metal parts, in the presence of shielding between the transmitter and the control unit or in the presence of other devices that communicate at the same radio frequency. 		
# TERMINAL	FUNCTION	
8	Antenna cable	Connect cable type RG58
9	Shield	

The control unit is supplied with a standard antenna already connected.

INSTALLATION ADVICE	
The RADIO LED on the board, allows to have a visual feedback of the amount of radio noise present in the surroundings of the automation. The more the LED is fixed and the greater the disturbances present.	 RADIO
In susceptible installations it is advisable to install an antenna at 433mhz. Install the external antenna and its cables in a place protected from damage and/or vibration and where there are no obstacles between the transmitters and the antenna.	

4.9 - ELECTRICAL CONNECTIONS BY THE MANUFACTURER

DANGER	
<ul style="list-style-type: none"> • The operation of replacing the control unit can be operated only by authorized and highly qualified personnel. • Before carrying out such operations make sure to operate in the absence of voltage and in total safety. 	

The connections described in this section are already made during the factory assembly of the gear motor. Refer to this table if you need to replace the control unit.

# TERMINAL	FUNCTION	RATING
1	GREY cable - Common (W)	Cable connection with SINGLE-phase electric motor.
2	BLACK cable - Phase 1 (V)	
3	BLUE cable - Phase 2 (U)	
1	BLUE cables - Phase 1 (W)	Cable connection with THREE-PHASE electric motor.
2	BLACK cables - Phase 2 (V)	
3	WHITE cables - Phase 3 (U)	
7	Earthing of the electronic board.	
10	BROWN Cable - Common LIMIT SWITCH	Contact clean (voltage free) Normally Closed. Signal LED Normally On.
16	RED cable - LSO limit switch contact	
17	GREEN Cable - LSC limit switch contact	

5. PROGRAMMING

DANGER

The operations described in this chapter to finalize the installation must be carried out in the presence of voltage, therefore they must be carried out only by experienced personnel, qualified and taking all necessary precautions to ensure safe execution.

Check that the operating area is free from any obstacles.



Once the electrical connections are finished, proceed with commissioning.

Give voltage and check that all the LEDs of safety are on.

Verify that the intervention of the safety switches off the corresponding LED.

If not, turn off the automation and check that the devices are properly connected and working.

5.1 - FUNCTION OF THE PROGRAMMING KEYS

1. UP button

The UP button allows you to perform the following operations:

- Start and finish the transmitter learning procedure.
- Navigate through the menu items.
- Increase a value.

2. MENU button

The MENU button allows you to perform the following operations:

- Enter and exit the menu.
- Confirm a choice.

3. DOWN button

The DOWN button allows you to perform the following operations:

- Change the display modes.
- Pause the learning of the stroke to reverse the direction of movement.
- Navigate through the menu items.
- Decrease a value.

4. SS button (Step-by-Step)

The SS button allows you to perform the following operations:

- Performs the STEP-BY-STEP function.

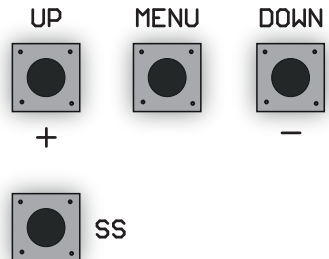

5.2 - DISPLAY MODE

The display available in the control unit allows you to see a lot of information such as the status of the automation, the number of movements performed, the anomalies detected, etc.

There are 4 types of views available.

To switch from one type to another press the DOWN button.

VIEW 1: STANDARD

In this mode you can view the automation status and error messages.

Refer to the next chapter for more information about the message type.

VIEW 2: NUMBER OF MOVEMENTS CARRIED OUT

In this mode you can see the number of cycles (opening and closing) performed by the automation.

The control unit will alternate two values: the first, without dots, indicates the thousands; the second, with dots, indicates the units.

For example:

00 1 = 1 thousand

02.0 = 20 units

Total = 1020 cycles completed.

VIEW 3: CURRENT ABSORBED BY THE MOTOR

In this mode you can see the current absorbed by the motor (mA).

VIEW 4: BOARD TEMPERATURE

In this mode you can view the temperature reached by the board expressed in °C.

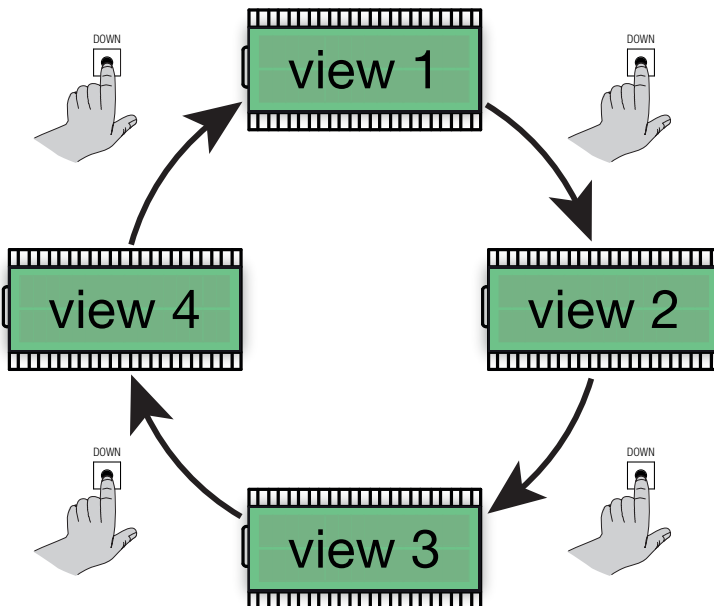

DISPLAY	DESCRIPTION
--	Standby after first connection of the supply voltage. Automation in CLOSED GATE position.
<i>oP</i>	Automation stops in OPEN GATE position, without automatic closing.
<i>PE</i>	Automation stops in the PARTIAL OPENING position, without automatic closing.
<i>OP</i>	Automation in opening movement.
<i>CL</i>	Automation in closing movement.
<i>SO</i>	Opening movement stopped by a user command.
<i>SC</i>	Closing movement stopped by a user command.
<i>HA</i>	Movement stopped by a safety device (EDGE, PH1, PH2 and STOP inputs) or impact sensor.
<i>-tC</i>	Automation stops in OPEN GATE position, with automatic closing. In the last 10 seconds the symbol " - " is replaced by the countdown.
<i>-tt</i>	Automation stops in OPEN GATE position, with automatic closing after transit. In the last 10 seconds the symbol " - " is replaced by the countdown.
<i>-tP</i>	Automation stops in the PARTIAL OPENING position, with automatic closing. In the last 10 seconds the symbol " - " is replaced by the countdown.
<i>LOP</i>	LEARNING OF THE STROKE - learning the opening movement.
<i>LCL</i>	LEARNING OF THE STROKE - learning the closing movement.
<i>L--</i>	LEARNING OF THE STROKE - Process in stand-by. Verify that all safety devices are functioning and correctly configured and that limit switches are not engaged. Give a Step-By-Step command to resume the procedure.
<i>rAd</i>	Waiting for a transmitter to be learned.
<i>don</i>	Procedure successfully completed.
<i>SEE</i>	Control unit waiting for a known radio command to display its position.
<i>Fnd</i>	Remote control already learned in the radio memory.
<i>CLr</i>	Cancellation of a remote control already learned happened successfully.
<i>toUt</i>	Output from the function in use for TIME-OUT.

DANGER**RISK OF IMPACT, CRUSHING, HOOKING AND ENTRAPMENT**

- Set the DEF parameter according to the type of gate to be moved.
- Make all necessary adjustments and checks in accordance with all applicable local, regional and national regulations and rules.

Failure to comply with these instructions will result in death or serious harm to persons and/or property.

**NOTE**

- This procedure returns all parameters to their default value. Check the correct setting of all the parameters in case you want to use accessories and special features of this unit.
- Once the configuration is finished you need to do the learning of the strokes procedure.











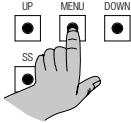
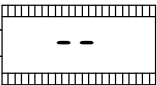
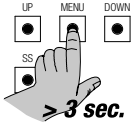

Use the advanced parameter DEF to load different configurations of parameters, based on the maximum weight of the gate to move. These configurations allow the gear motor to reach different adjustable speeds.

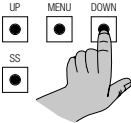
The control unit is configured with the DEF parameter at value 0.

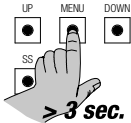
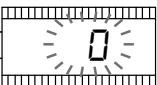
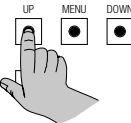
Below is the table of parameters modified by the DEF parameter.

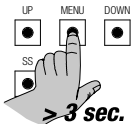
DEF	GATE WEIGHT	PARAMETER	VALUES	DEFAULT
0	MAX 2200 Kg	SP _n	From 30 to 100 Hz	50 Hz
		SPL	From 20 to 40 % of SP _n	30 % of SP _n
1	MAX 1200 Kg	SP _n	From 30 to 110 Hz	60 Hz
		SPL	From 20 to 40 % of SP _n	25 % of SP _n
2	MAX 800 Kg	SP _n	From 30 to 130 Hz	60 Hz
		SPL	From 20 to 40 % of SP _n	25 % of SP _n
3	MAX 500 Kg	SP _n	From 30 to 150 Hz	75 Hz
		SPL	From 20 to 40 % of SP _n	20 % of SP _n

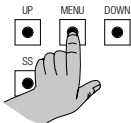
CONFIGURATION PROCEDURE

1.	<p>Make sure you are out of the programming menus. To exit, briefly press the MENU key until you see the status of the control panel.</p>		
2.	<p>Access the advanced menu by holding down the MENU key for at least 5 seconds.</p>	 <p>> 3 sec.</p>	
3.	<p>Press the DOWN button several times until the DEF parameter appears.</p>		
4.	<p>Hold down the MENU key for at least 3 seconds The set value flashes.</p>	 <p>> 3 sec.</p>	
5.	<p>Use the UP and DOWN keys to select the desired value. (for example "1").</p>		
6.	<p>Press and hold the MENU key for 3 seconds to confirm. The value stops flashing.</p>	 <p>> 3 sec.</p>	
7.	<p>Release the MENU key and then press and hold the MENU key. A countdown is displayed. DO NOT RELEASE THE MENU KEY DURING THIS STEP.</p>		
8.	<p>At the end of the countdown, the word "don" appears to confirm the correct execution of the procedure. To exit, briefly press the MENU key until you see the status of the control panel.</p>		

5.5 - LEARNING OF A REMOTE CONTROL

The learning of a transmitter can be activated via the UP button of the control unit or via the hidden button of a transmitter already stored.

The control unit can store up to 1000 remote controls (with memory card) and each of them can associate up to 4 functions, no more than one function per key available. During the learning procedure a single function is stored in a transmitter button. To assign all 4 available functions you will need to repeat the procedure 4 times.

Functions are assigned in the following order:

- 1st stored key: STEP-BY-STEP function.
- 2nd stored key: PARTIAL OPENING function.
- 3rd stored key: OPEN function.
- 4th stored key: CLOSE function.

STANDARD LEARNING OF A TRANSMITTER

NOTE

- To store a new remote control or a new function on the same remote control, repeat the procedure from step 2.
- After 10 seconds of inactivity the control panel leaves the learning mode and the display shows "E00E".



1.	Make sure you are out of the programming menus. To exit, briefly press the MENU key until you see the status of the control panel.		
2.	While the automation is stopped, press and release the UP button. The word "rAd" appear on the display. The flashing light comes on.		
3.	Within 10 seconds, press the transmitter button to learn.		
4.a	If the remote control is the first time it is learned, the word "don" appears in the display. The STEP-BY-STEP function is associated with the pressed button. The flashing light flashes 2 times.		
4.b	If the remote control was already stored in the control unit, the words "Fnd" appear in the display. The pressed key is associated with the function PARTIAL OPENING, OPEN or CLOSE depending on how many times this procedure has been repeated. The flashing light flashes 1.		
5.	After 2 seconds the display shows the memory position where the remote control was stored (for example "235").		

LEARNING WITH THE HIDDEN BUTTON OF A TRANSMITTER ALREADY LEARNED

NOTE

- The use of the hidden button, if present, of a transmitter already learned involves the entry in learning mode of all the units in which it is associated. Make sure that unwanted radio controls are not learned.
- This procedure is not available for all transmitter types. Please refer to your transmitter installation manual.



When automation is stopped you can press the hidden button of a transmitter already learned to open the radio memory of the control unit. This is equivalent to pressing the UP button on the control unit.

Then follow the learning procedure from point 3 to 5 of the previous paragraph.

CANCELLATION OF A TRANSMITTER ALREADY LEARNED BY HIDDEN BUTTON

NOTE

- This procedure is not available for all transmitter types. Please refer to your transmitter installation manual.
- After 10 seconds of inactivity the control panel leaves the learning mode and the display shows "E05E".



1.	Make sure you are out of the programming menus. To exit, briefly press the MENU key until you see the status of the control panel.		
2.	While the automation is stopped, press and release the UP button or the hidden button of a transmitter already learned. The word "rAd" appear on the display.		
3.	Within 10 seconds, simultaneously press the first button and the hidden button of the transmitter to be deleted.		
4.	If the cancellation is successful, the words "ELr" appear on the display. The flashing light flashes 4 times.		
5.	After 2 seconds the display shows the location of the erased memory (for example "235").		

5.6 - LEARNING OF THE STROKES



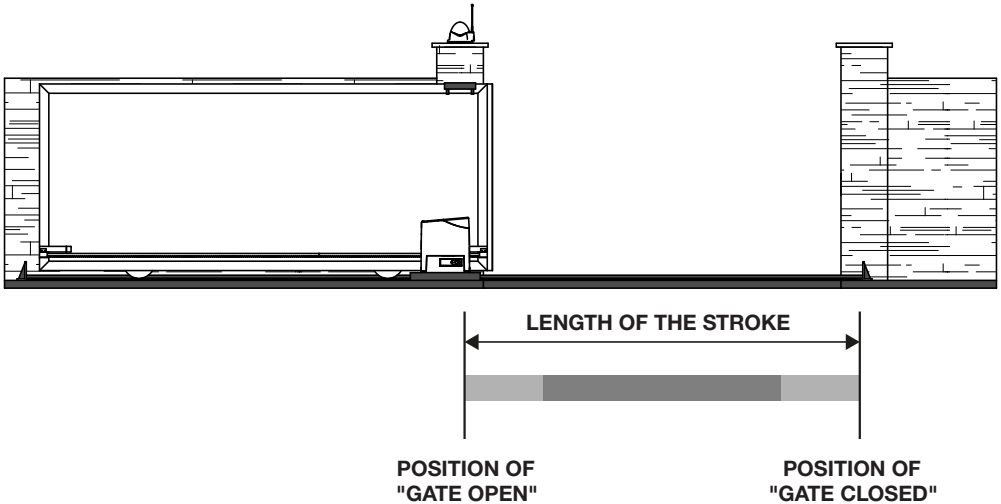



At the first installation it is necessary to perform a learning procedure to detect the total length of the stroke, the length of the slowdowns and all other areas of the installation necessary for the correct operation of the automation.



	Handling area at slowdown speed.
	Handling area at normal speed.



ADJUSTMENT OF LIMIT SWITCH POSITIONS

Perform some movements of the mobile door to adjust the position of the electro-mechanical limit switches and verify the correct connection in the control unit.





LED	DESCRIPTION	POSITION
LSO LSC  	LSO LIMIT SWITCH ACTIVE LED LSO - OFF LED LSC - ON	Gate in position of "OPEN GATE"
LSO LSC  	LIMIT SWITCHES NOT ACTIVE LED LSO - ON LED LSC - ON	Gate in intermediate position
LSO LSC  	LSC LIMIT SWITCH ACTIVE LED LSO - ON LED LSC - OFF	Gate in position of "CLOSED GATE"

STANDARD LEARNING

With standard learning, the control unit performs all the procedure and the calculation of slowdowns, which will be set with the same amplitude both in opening and closing (see basic parameter " L5 ,").

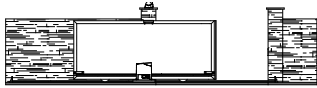
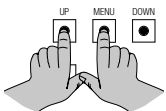

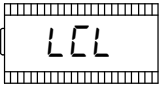
 DANGER 	
<ul style="list-style-type: none"> • Check that during the first movement the display displays " LDP " and the gate moves in the OPENING DIRECTION. If necessary, press the DOWN button and then the SS button to reverse the movement. • In order for the automation and all the safety devices installed to function correctly, it is necessary to verify the correct direction of the automation movement. 	 

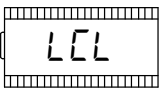
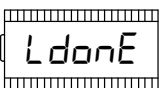
 NOTE 	
<ul style="list-style-type: none"> • <i>If the procedure starts while the limit switches are active, or if a safety device is involved during movement, the procedure is stopped and the words " L - - " appear on the display.</i> <p><i>Carry out the appropriate checks and press the SS button to resume learning from step 3.</i></p>	







1.	<p>Unlock the transmission of the motor and manually bring the gate in mid-stroke. Then insert the motor transmission again.</p>	
2.	<p>Press the UP button and the MENU button simultaneously for at least 5 seconds until the display shows " LDP ". At this stage the gear motor moves in search of the opening limit switch. Verify that the automation moves in the opening direction.</p>	 
3.	<p>Once the opening limit switch has been reached, the automation automatically moves in closing, at low speed, until the closing limit switch is reached. At this stage the display shows " LCL " .</p>	
4.	<p>Once the closing limit switch has been reached, the automation automatically moves in opening, at low speed, until the opening limit switch is reached. At this stage the display shows " LDP " .</p>	
5.	<p>Once the opening limit switch has been reached, the automation moves in closing at full speed and with the slowdowns set by the menu through the " L5 , "parameter.</p>	
6.	<p>After the procedure the control unit displays " LdonE "</p>	

LEARNING WITH PERSONALIZED SLOWDOWNS

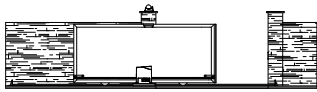
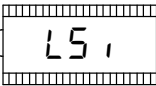
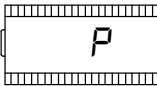
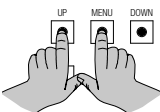
With personalised learning, the slowdowns should be set during the learning process and the amplitudes in both directions will be independent.

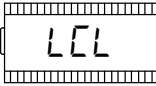
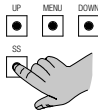
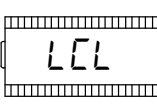
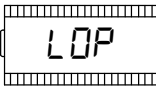
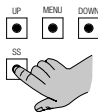
 DANGER 	
<ul style="list-style-type: none"> • Check that during the first movement the display displays "LDP" and the gate moves in the OPENING DIRECTION. If necessary, press the DOWN button and then the SS button to reverse the movement. • In order for the automation and all the safety devices installed to function correctly, it is necessary to verify the correct direction of the automation movement. 	 

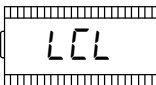
 NOTE 	
<ul style="list-style-type: none"> • <i>If the procedure starts while the limit switches are active, or if a safety device is involved during movement, the procedure is stopped and the words "L - - " appear on the display.</i> <i>Carry out the appropriate checks and press the SS button to resume learning from step 3.</i> 	

1.	Unlock the transmission of the motor and manually bring the gate in mid-stroke. Then insert the motor transmission again.		
2.	Set the P value to the L51 parameter in the base menu to enable the function.		
3.	Press the UP button and the MENU button simultaneously for at least 5 seconds until the display shows "LDP". At this stage the gear motor moves in search of the opening limit switch. Verify that the automation moves in the opening direction.		
4.	Once the opening limit switch is reached, the automation automatically moves into closing at low speed. At this stage the display shows "LCL".		
5.	When the automation reaches the desired slowdown start position press the SS button. The automation proceeds at reduced speed until the closing limit switch is reached and the flashing light remains fixed.		
6.	Once the closing limit switch is reached, the automation automatically moves into the opening at low speed. At this stage the display shows "LDP".		
7.	When the automation reaches the desired slowdown start position press the SS button. The automation proceeds at reduced speed until the opening limit switch is reached and the flashing light remains fixed.		
8.	Once the opening limit switch has been reached, the automation moves in closing at full speed and with customized slowdowns.		
9.	After the procedure the control unit displays "LdonE"		

5.7 - MENU OF BASIC FUNCTIONS

To access the basic function menu, press and hold the MENU button for 1 to 3 seconds.

Use the UP and DOWN buttons to scroll through the available features.

While displaying a function, the control unit will alternate the display of the item to the value set in it.

To change the value of the parameter you are viewing proceed as follows:

- Press and hold the MENU button for at least 3 seconds, the currently set value flashes.
- Use the UP and DOWN buttons to select the desired value.
- Confirm the value by holding down the MENU button for at least 3 seconds.

To exit, press the MENU button quickly.

NOTE	
<ul style="list-style-type: none"> • The values in this chapter refer to the configuration with advanced parameter DEF = 0 	

PARAMETER LIST

Automatic Closing

NOTE	
<ul style="list-style-type: none"> • When used in conjunction with the parameter "Automatic Closing after Transit", the parameter "Automatic Closing" is not considered. • This parameter does not affect if the gate reaches the position of "PARTIAL OPENING". 	

Set an automatic closing time.

Once reached the position of "GATE OPEN" the control unit starts the countdown by displaying on the screen "- E c" (the symbol "-" is replaced by a number in the last 10 seconds of the countdown).

In case the photocell input is active the countdown is restored and remains locked until contact is restored.

PARAMETER	VALUES	DEFAULT
E c L	OFF = disabled. From 1 to 900 seconds.	OFF

Automatic Closing after Transit

NOTE	
<ul style="list-style-type: none"> • When used together with the parameter "Automatic Closing", that is not considered. • This parameter does not affect if the gate reaches the position of "PARTIAL OPENING". 	

Set an automatic closing time after the passage.

Once reached the position of "GATE OPEN" the control unit is waiting and displays "- E E".

The countdown starts only after the engagement and subsequent disengagement of the PH1 photocell input.

The symbol "-" is replaced by a number in the last 10 seconds of the countdown.

In case the photocell input is active the countdown is restored and remains locked until contact is restored.

PARAMETER	VALUES	DEFAULT
E E r	OFF = disabled. From 1 to 30 seconds.	OFF

Obstacle sensitivity on full speed movement

NOTE	
<ul style="list-style-type: none">• Too high a level of sensitivity could cause an abnormal behaviour of the automation depending on the force that the gear motor needs to move the automation.• Adjust this parameter according to current regulations.	

Set the sensitivity level for the impact sensor to intervene during gate movement.
The impact sensor controls a short reversal of movement to free the obstacle.

PARAMETER	VALUES	DEFAULT
SE_n	OFF = disabled. From 1 to 100 %	30 %

Obstacle sensitivity on slow speed movement

NOTE	
<ul style="list-style-type: none">• Too high a level of sensitivity could cause an abnormal behavior of the automation depending on the force that the gear motor needs to move the automation.• Adjust this parameter according to current regulations.	

Set the sensitivity level to make the impact sensor intervene during the movement of the gate during slowdown.
The impact sensor intervention during slowdown controls a short reversal of the movement to free the obstacle.

PARAMETER	VALUES	DEFAULT
SE_L	OFF = disabled. From 1 to 100 %	50 %

Normal Speed

Set the speed of the motor movement during the normal speed area.
This value is expressed as a frequency.

PARAMETER	VALUES	DEFAULT
SP_n	From 30 to 100 Hz	50 Hz

Slowdown Speed

Set the speed of the motor movement during the slowdown area.
This value is expressed as a percentage of the "Normal Speed".
Changing the parameter "Normal Speed" also affects the parameter "Slowdown Speed".

PARAMETER	VALUES	DEFAULT
SPL	From 20 to 40 % of SP_n	30 % of SP_n

Configuration of the STEP-BY-STEP function

NOTE	
<ul style="list-style-type: none">• By setting the CONDOMINIUM functionality you must set an automatic closing time to make the gate close.	

Customize the action mode of the STEP-BY-STEP function.

Normal: ("OPEN" - "STOP" - "CLOSE" - "STOP" - ...)

Classic operation of the STEP-BY-STEP mode. During handling, a STEP-BY-STEP control involves stopping the automation.

Alternate STOP: ("OPEN" - "STOP" - "CLOSE" - ...)

Alternating operation with STOP in opening. During opening handling, a STEP-BY-STEP control involves stopping the automation. During the closing movement performs a reversal of motion.

Alternate: ("OPEN" - "CLOSE" - ...)

In this mode, the user does not have the possibility to stop the automation with a STEP-BY-STEP control, but instead a reversal is obtained.

Condominium (Timer): ("OPEN" - ...)

The STEP-BY-STEP control allows only a complete opening of the automation. If the command persists with the automation in the OPEN GATE position, it will wait for the release before starting the timing for automatic closing. Each press of the STEP-BY-STEP control restores the countdown.

Condominium with immediate close: ("OPEN" - ...)

If the automation is not in the OPEN GATE position, the STEP-BY-STEP control allows a complete opening of the automation. When the automation is in the OPEN GATE position, a STEP-BY-STEP command immediately closes the automation, resetting the automatic closing timer if present.

PARAMETER	VALUES	DEFAULT
<i>SbS</i>	0 = Normal. 1 = Alternate STOP. 2 = Alternate. 3 = Condominium (timer). 4 = Condominium with immediate close.	0 = Normal

Behaviour after Black-out

Allows to automatically execute a closing command to reset the main supply voltage, following a Black-out. This movement is always carried out at slow speed, until the "CLOSED GATE" position is reached.

PARAMETER	VALUES	DEFAULT
<i>blt</i>	OFF = No action performed. ON = Automatically execute a "CLOSE" command.	OFF

Width of the slowdown area

Adjusts the width of the opening and closing slowdown area as a percentage of the total stroke length.

With the value "P" you can set custom areas during the learning of the races (see paragraph LEARNING WITH PERSONALIZED SLOWDOWNS).

PARAMETER	VALUES	DEFAULT
<i>LSI</i>	From 5 to 100 % of the total stroke length. P = Personalized areas.	10 %

Anti-skid function

It allows you to add extra working time compared to that stored during the course learning procedure, so as to ensure the complete closure of the automation even if the working time learned is not enough to get to the position of "CLOSED GATE".

PARAMETER	VALUES	DEFAULT
<i>ASL</i>	OFF = disabled. From 1 to 300 seconds.	15 seconds.

5.8 - MENU OF ADVANCED FUNCTIONS

To access the advanced features menu, press and hold the MENU button for longer than 5 seconds.

Use the UP and DOWN buttons to scroll through the available features.

While displaying a function, the control unit will alternate the display of the item to the value set in it.

To change the value of the parameter you are viewing proceed as follows:

- Press and hold the MENU button for at least 3 seconds, the currently set value flashes.
- Use the UP and DOWN buttons to select the desired value.
- Confirm the value by holding down the MENU button for at least 3 seconds.

To exit, press the MENU button quickly.

NOTE	
<ul style="list-style-type: none"> • The values in this chapter refer to the configuration with advanced parameter DEF = 0 	

PARAMETER LIST

Mode of intervention of the impact sensor

NOTE	
<ul style="list-style-type: none"> • Adjust this parameter according to current regulations. 	

Determines which areas of the stroke the impact sensor is active.

PARAMETER	VALUES	DEFAULT
S_{ni}	OFF = Disabled. 1 = Normal and slowdown areas. 2 = Only normal speed area. 3 = Only slowdown speed area.	2 = Only normal speed area.

Intervention time of the impact sensor

It determines how long the impact sensor takes after the obstacle has been reached (motor blocked).

PARAMETER	VALUES	DEFAULT
S_{it}	From 1 to 10 multiplied by 100 ms	2 = 200 ms

Time to disable impact sensor at movement begin

Determines how long the impact sensor is disabled at the start of handling.

PARAMETER	VALUES	DEFAULT
S_{dt}	From 1 to 30 multiplied by 100 ms	15 = 1500 ms

Mode of intervention PH1 photocell input

During the closing movement the engagement of the connected photocell on the input PH1 always involves the reversal of the motion and consequent handling up to the position of "OPEN GATE".

Moreover, during the opening movement, the photocell input does not cause any intervention of the control unit.

With this parameter it is possible to customize the behavior of the control unit following the intervention of the photocell, in case the automation is stopped in the position of "CLOSED GATE".

Value 0: The automation doesn't start if the PH1 input is engaged.

Value 1: The automation moves in opening even if the PH1 input is engaged.

PARAMETER	VALUES	DEFAULT
<i>SPh</i>	0 = Check input PH1 when "CLOSED GATE". 1 = Ignore input PH1 when "CLOSED GATE".	1

Mode of intervention PH2 photocell input

The engagement of the connected photocell on the PH2 input always involves the temporary stop of the movement, until the photocell is released. Once released, automation always moves in the direction of opening.

With this parameter you can customize when this behaviour is enabled.

Value 0: Enabled during opening and closing movement.

Value 1: Only enabled during the opening movement.

PARAMETER	VALUES	DEFAULT
<i>Ph2</i>	0 = Enabled in both opening and closing. 1 = Only enabled on opening.	0

Function of self-test of photocells

NOTE

- To properly use this function you need to use terminal number 23 to power the transmitter photocell.



By enabling this function it is possible to make the control unit perform a functional test of the photocells before each movement. The test, if enabled, is not performed in case of fast reversals.

PARAMETER	VALUES	DEFAULT
<i>tPh</i>	OFF = Disabled. 1 = Enabled for input PH1 2 = Enabled for input PH2 3 = Enabled for both inputs PH1 and PH2	OFF

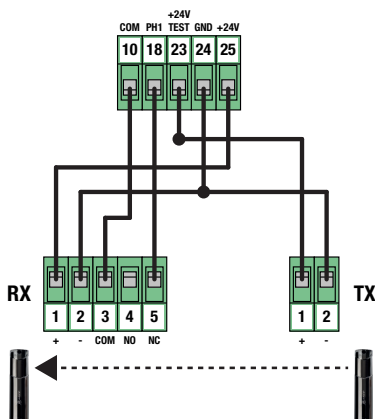

Type of safety edge installed

Select the type of security edge connected to the EDGE input.

PARAMETER	VALUES	DEFAULT
Edi	0 = Mechanical type (Contact Normally Closed) 1 = Resistive type (8.2 Kohm)	0

Mode of intervention EDGE input

Customize the behaviour of the control unit following the intervention of the device connected to the EDGE input.

Value 0: Only during the closing movement, performs a reversal of motion until reaching the position of "OPEN GATE".

Value 1: During any movement, it stops the automation and then a short reversal to free the obstacle.

PARAMETER	VALUE	DEFAULT
iEd	0 = Total reversal of motion (closing only). 1 = Stop and short motion reversal.	0

Reversal time on EDGE input intervention

It determines how long the gear motor performs the movement in the opposite direction following the stop caused by the intervention of the EDGE input (only with $iEd = 1$).

PARAMETER	VALUES	DEFAULT
ErE	From 5 to 20 multiplied by 100 ms	10 = 1000 ms

Auto-test function of safety edge

NOTE

- To use this function correctly it is necessary to connect a device with electronic test circuit (e.g. R.CO.0). Connect the device test contact to terminal 23 of the control unit, and enable the test with the low logic level 0Vdc.



By enabling this function it is possible to make the control unit perform a functional test of the safety edge before each handling.

PARAMETER	VALUES	DEFAULT
tEd	OFF = Disabled. ON = Enabled.	OFF

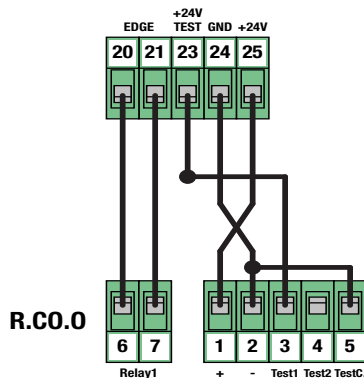

Amplitude of partial opening

Adjusts the amplitude of the partial opening as a percentage of the total stroke length.

Partial opening is possible only starting from the position of "CLOSED GATE", using the appropriate command. Once reached the position of "PARTIAL OPENING" the display displays "PE".

PARAMETER	VALUES	DEFAULT
LPO	OFF = disabled. From 1 to 100 % of the total stroke length.	30 %

Automatic Closing by Partial Opening

Set a waiting time before the control unit controls an automatic closing after reaching the "PARTIAL OPENING" position.

Once reached the position of "PARTIAL OPENING" the control unit starts the countdown by displaying on the screen "-EPC" (the symbol "-" is replaced by a number in the last 10 seconds of the countdown).

In case the photocell input is active the countdown stops until the contact is restored.

PARAMETER	VALUES	DEFAULT
EPC	OFF = disabled. From 1 to 900 seconds.	OFF

Configuration of the Flashing light output

Customize the behaviour of the flashing light output according to the type of connected device.

PARAMETER	VALUES	DEFAULT
FPr	0 = Flashing with self-flashing circuit. 1 = Flashing without self-flashing circuit.	1

Flashing time before handling

Set how long the flashing output is activated before starting the movement.

PARAMETER	VALUES	DEFAULT
EPr	OFF = disabled. From 1 to 10 seconds.	OFF

Courtesy light output configuration

Customize the mode of action of the courtesy light output.

Value 0: The light goes out at the end of a manoeuvre, after waiting for the time set in the parameter $ECLY$.

Value 1: The light turns off at automation in the position of "CLOSED GATE", after waiting for the time set in the parameter $ECLY$.

Value 2: With each command received, the light remains on only for the time set in the $ECLY$ parameter. WARNING: The light may turn off before the end of the movement.

Value 3: Open automation indicator function. The light turns off when the automation reaches the "CLOSED GATE" position.

Value 4: Open automation indicator function with blink proportional to the state of the automation. In detail:

- Opening movement = slow flashing.
- Closing movement = fast flashing.
- Position of "OPEN GATE" = light on.
- Position of "CLOSE GATE" = light off.
- Gate stopped in intermediate position = alternates two flashes and a long pause.

PARAMETER	VALUES	DEFAULT
<i>FCY</i>	0 = Light on during operation + tCY 1 = Light off in "CLOSED" after tCY 2 = Light on for tCY 3 = Light off in "CLOSED" 4 = Proportional flashing	0

Time for Courtesy Light

Set a time to activate or wait for the courtesy light. Use it in combination with the "Courtesy light output configuration" parameter.

PARAMETER	VALUES	DEFAULT
<i>ECY</i>	OFF = disabled. From 1 to 900 seconds.	180 seconds.

Maintained control function (DEAD-MAN MODE)

Enables the possibility to move the automation only by holding the desired command. Once the command is released, the automation stops. Activating this function results in the following functional changes:

- The "Step-by-Step" and "Partial Opening" commands are disabled.
- All security inputs except "STOP" are disabled.
- All automatic operations set, including automatic closures and reversals movements are disabled.
- The commands "OPEN" and "CLOSE" remain active both radio and rows.

PARAMETER	VALUES	DEFAULT
<i>dEA</i>	OFF = Disabled. ON = Enabled.	OFF

Cycle threshold for service request

It allows you to set a number of cycles, after which the control unit will signal the achievement of the threshold by replacing the normal flashing during movements, with a fast flashing.

This parameter shall be used in combination with the parameter "Flashing for service request".

PARAMETER	VALUES	DEFAULT
<i>SEr</i>	OFF = Disabled. From 1 to 100 multiplied by 1000 cycles.	OFF

Flashing light for service request

Enable flashing for service request.

PARAMETER	VALUES	DEFAULT
<i>SEF</i>	OFF = Disabled. ON = Enabled.	OFF

Mode of use electrical lock

Enables the use of the electro-lock output and allows you to set the activation time before handling. This output does not give supply power to the device and therefore it is necessary to use an external power source.

PARAMETER	VALUES	DEFAULT
<i>ELi</i>	OFF = Disabled. From 1 to 20 multiplied by 100 ms	OFF

Function of Mechanical Relaxation

It allows you to perform a short reversal, the duration of which is customizable, once you reach the limit switch of opening or closing. This function is useful in case automation presses the mechanical blocks too hard and makes manual unlocking difficult.

PARAMETER	VALUES	DEFAULT
<i>irE</i>	OFF = Disabled. From 1 to 20 multiplied by 100 ms	OFF

Function of Soft Stop

It allows to adjust the deceleration ramp in case of request of stop by user command or in case of intervention of the photocell inputs (PH1 and PH2). This parameter DOES NOT modify the deceleration ramp in case of intervention of the EDGE (safety edge) and STOP input.

PARAMETER	VALUES	DEFAULT
<i>Sft</i>	From 6 to 20 multiplied by 100 ms	10 = 1000 ms

Modbus Address

Address attribute to the control unit to establish a MODBUS communication.

PARAMETER	VALUES	DEFAULT
<i>ibAdr</i>	From 0 to 247	0 = OFF

Reset to the Default Values (RESET)

It performs a reset of the control unit and sets the values of all the basic and advanced parameters, bringing them to the default ones.

This function DOES NOT cancel the learned run and DOES NOT erase the learned remotes.

To perform the reset follow below steps:

- Access the parameter by holding the MENU button for 3 seconds.
- When the display displays the value "0" release the button.
- Press the MENU button and hold it until the countdown ends and the display displays "don".
- The procedure was successfully completed.

PARAMETER	VALUES	DEFAULT
<i>dEF</i>	0 = MAX 2200 Kg 1 = MAX 1200 Kg 2 = MAX 800 Kg 3 = MAX 500 Kg	0

Viewer memory location of a learned transmitter

With this parameter you can view the memory location assigned to a transmitter by the control unit during learning. To do this follow the following steps:

- Access the parameter by holding the MENU button for 3 seconds.
- When the display displays the value "5EE" release the button.
- From this moment, the control unit is waiting for a known radio command. WARNING: after 15 seconds without receiving any transmission, the control unit automatically exits the function by displaying the message "tOLt".
- Transmit with your own remote control, the display will display the memory position (for example "245").
- More than one remote control can be displayed in the same session. To exit the function, briefly press the MENU button.

PARAMETER	VALUES	DEFAULT
<i>tS</i>		

Cancellation of a single transmitter learned

With this parameter you can erase a single transmitter already learned, using its memory location. If this value is not known, refer to the function "Display memory position of a learned transmitter".

Follow these steps to cancel:

- Access the parameter by holding down the MENU button for 3 seconds.
- When the display displays the value " 0 " release the button and use the UP and DOWN buttons to set the memory position of the remote to be erased.
- Confirm by holding down the MENU button for 3 seconds.
- The display will display the message " CLR " to indicate the correct deletion.
- If the memory location is empty the message " Err " will appear.
- You can delete more than one remote control in the same session. To exit the function, press the MENU button briefly.

PARAMETER	VALUES	DEFAULT
ErC		

Deletion of all radio memory

With this parameter it is possible to reset the radio memory.

This will erase ALL the transmitters learned.

To perform total cancellation follow these steps:

- Access the parameter by holding down the MENU button for 3 seconds.
- When the display displays the value " 0 " release the button.
- Press the MENU button and hold it until the countdown ends and the display displays " don ".
- The procedure was successfully completed.

PARAMETER	VALUES	DEFAULT
ErF		

6. ERROR MESSAGES

NOTE

Message reporting persists as long as the event persists or until the DOWN button is pressed or a handling command is executed.



DISPLAY	DESCRIPTION	SOLUTION
<i>ELS</i>	Limit switch error: Opening and closing limit switches occupied simultaneously, or locked.	<ul style="list-style-type: none"> • Check that the limit switch is not blocked. • Check electrical connections and limit switch integrity. • Check the integrity of the fuses.
<i>EFD</i>	Movement stopped by the impact sensor. Effort too high to allow movement of the gate.	<ul style="list-style-type: none"> • Check the integrity and good condition of the entire gate and automation. • Remove any dirt or foreign matter that may hinder movement. • Adjust the sensitivity parameters of the impact sensor.
<i>EE_d</i>	Movement stopped by the intervention of the safety edge (EDGE input).	<ul style="list-style-type: none"> • EDGE input activated. • Verify that the device connected to the EDGE input is working properly and configured.
<i>E_{th}</i>	Thermal intervention to safeguard the board.	<ul style="list-style-type: none"> • Wait for the automation to cool down before performing further handling. • Please ensure that you do not exceed the use threshold indicated in this user manual.
<i>E_{TE}</i>	Error in remote control memory. Memory not installed or not recognized.	<ul style="list-style-type: none"> • Remove and insert the remote control memory again. • Perform the remote control memory reset procedure (TRF parameter). • Replace the remote control memory with a new one.
<i>FUL</i>	Full remote control memory. It is no longer possible to learn more remote controls.	<ul style="list-style-type: none"> • Clear some remote controls. • Replace the remote control memory with a new one.
<i>E_{rr}</i>	Error in memory query during learning functions, position display or transmitter deletion.	<ul style="list-style-type: none"> • Incorrect selected memory location. • Replace the remote control memory with a new one.
<i>E_{bs}</i>	Overcurrent error on motor output.	<ul style="list-style-type: none"> • Switch off the system and verify that the connected motor is suitable for the type of control unit in use and that there are no short circuits or malfunctions on the engine in use. • If the error persists contact technical support.

7. MAINTENANCE

DANGER

- Before carrying out any cleaning, maintenance or replacement of parts, remove power to the automation.
- The following points are specific to the maintenance of the gear motor. The list does not cover maintenance activities specific to the sliding gate/door.



NOTE

- *If the system is not used for long periods, for example in the case of installations in places with seasonal opening, the power should be switched off and, upon restoration, the correct operation should be checked.*
- *To view the number of manoeuvres, refer to the chapter "DISPLAY MODE".*



Every 10,000 cycles and in any case every 6 months of activity, the following maintenance interventions are mandatory:

- Check and clean any dirt, insects and dust residues that have positioned themselves within the automation. In particular, check that the heat sink and fan are in good condition and clean.
- Check the integrity of the cables and their connections and make the necessary replacements.
- Check the efficiency of the release lever, performing some manual manoeuvres. The gate must not find any obstacles.
- Perform a general and complete check of the screws and bolts.
- Lubricate all moving mechanical parts.
- Check the proper functioning of signalling and safety devices.
- Check the wear status of the moving mechanical parts and check their correct functioning.
- Check and clean the slide rail and rack.

8. PRODUCT DISPOSAL

This product is an integral part of automation, and therefore, must be disposed of together with it. As for installation operations, even at the end of the life of this product, dismantling operations must be carried out by qualified personnel. This product consists of various types of materials: some can be recycled, others must be disposed of. Find out about the recycling or disposal systems required by the regulations in force in your territory, for this category of product.

WARNING

- Parts of the product may contain pollutants or dangerous substances which, if dispersed in the environment, could cause harmful effects on the environment itself and human health. As indicated by the symbol on the side, it is forbidden to throw this product in household waste. Then carry out the "separate collection" for disposal, according to the methods provided for by the regulations in force in your territory, or return the product to the seller when purchasing a new equivalent product.
- Local regulations may provide for heavy penalties in the event of improper disposal of this product.



9. WARRANTY

The manufacturer's warranty is valid by law from the date stamped on the product and is limited to the repair or replacement free of charge of the parts recognized by the same as defective due to lack of essential qualities in the materials or due to lack of processing. The warranty does not cover damage or defects due to external agents, lack of maintenance, overload, natural wear, incorrect choice of type, assembly error, or other causes not attributable to the manufacturer. Tampered products will not be guaranteed or repaired. The data reported are purely indicative. No liability may be charged for flow reductions or malfunctions due to environmental interference. The liability of the manufacturer for any damage caused to anyone by accidents of any nature caused by our defective products, are only those that derive from law.

10. DECLARATION OF INCORPORATION



ALLMATIC S.r.l
Via dell'Artigiano, n°1 – Z.A.
32026 Borgo Valbelluna - Belluno – Italy
Tel. 0437 751175 – 751163 r.a.
<http://www.allmatic.com> - e-mail: info@allmatic.com

DICHIARAZIONE DI INCORPORAZIONE - DECLARATION OF INCORPORATION - DECLARATION D'INCORPORATION - DECLARACIÓN DE INCORPORACIÓN

ALLMATIC S.r.l. Dichiaro sotto la propria responsabilità che:
ALLMATIC S.r.l. declares under its own responsibility that:
ALLMATIC S.r.l. Déclare sous sa responsabilité que:
ALLMATIC S.r.l. Declara bajo su propia responsabilidad que:

• Il prodotto TRAKTOR /I MOTORIDUTTORE PER CANCELLI SCORREVOLI FINO A 2200 KG è conforme alle seguenti norme: - The product TRAKTOR /I GEAR MOTOR FOR SLIDING GATES UP TO 2200 KG complies with the following standards: - Le produit TRAKTOR /I MOTOREDUCTEUR POUR PORTAILS COULISSANTS JUSQU'À 2200 KG est conforme aux normes suivantes: - El producto TRAKTOR /I MOTORREDUCTOR PARA PUERTAS CORREDERAS HASTA 2200 KG se ajusta a las siguientes normas:

EN 60335-1
EN 301489-1 V2.2.3 (2019-11)
EN 301489-3 V2.1.1 (2019-03)
EN 300220-2 V3.2.1 (2018-06)

Il che conferiscono presunzione di conformità ai requisiti stabiliti dalle Direttive: - This confers a presumption of conformity with the requirements laid down in the Directives: - Ça confère une présomption de conformité aux exigences fixées par les directives: - Lo que confiere presunción de conformidad con los requisitos establecidos por las Directivas:

2014/53/EU
2014/35/UE

• Il prodotto TRAKTOR /I MOTORIDUTTORE PER CANCELLI SCORREVOLI FINO A 2200 KG si configura ai sensi della direttiva 2006/42/CE come quasi-macchina idonea ad essere incorporata / integrata / assemblata in una macchina; al prodotto l'applicazione della direttiva 2006/42/CE è limitato ai seguenti requisiti essenziali di sicurezza: - The product TRAKTOR /I GEAR MOTOR FOR SLIDING GATES UP TO 2200 KG is configured according to Directive 2006/42/EC as a quasi-machine suitable to be incorporated / integrated / assembled in a machine; the product is subject to the following essential safety requirements: - Le produit TRAKTOR /I MOTOREDUCTEUR POUR PORTAILS COULISSANTS JUSQU'À 2200 KG est configuré selon la directive 2006/42/CE comme quasi-machine apte être incorporée / intégrée / assemblée dans une machine; l'application de la directive 2006/42/CE est limitée aux exigences essentielles de sécurité suivantes: - El producto TRAKTOR /I MOTORREDUCTOR PARA PUERTAS CORREDERAS DE HASTA 2200 KG se configura, con arreglo a la Directiva 2006/42/CE, como una cuasi máquina apta para ser incorporada / integrada / ensamblada en una máquina; La aplicación de la Directiva 2006/42/CE al producto se limita a los siguientes requisitos esenciales de seguridad:

1.2.1 Sicurezza ed affidabilità dei sistemi di comando
1.2.3 Arresto
1.2.6 Guasto del circuito di alimentazione di energia
1.5.1 Energia elettrica
1.7 Informazioni

Pertanto non deve essere messo in servizio finché la macchina finale in cui deve essere incorporata non è stata dichiarata conforme alle disposizioni della direttiva macchine 2006/42/CE. - It should therefore not be put into service until the final machinery in which it is to be incorporated has been declared to comply with the provisions of Machinery Directive 2006/42/EC. - Il ne doit donc pas être mis en service tant que la machine finale dans laquelle il doit être incorporé n'a pas été déclarée conforme aux dispositions de la directive machines 2006/42/CE. - Por consiguiente, no debe ponerse en servicio hasta que la máquina final en la que vaya a incorporarse haya sido declarada conforme con las disposiciones de la Directiva 2006/42/CE sobre máquinas.

ALLMATIC S.r.l., riferimento per la documentazione tecnica pertinente si impegna a trasmettere, in risposta a una richiesta adeguatamente motivata delle autorità di controllo, informazioni pertinenti alla quasi macchina. - ALLMATIC s.r.l., the reference for the relevant technical documentation, undertakes to transmit, in response to a duly reasoned request from the control authorities, information relevant to the quasi machine. - ALLMATIC s.r.l., référence de la documentation technique pertinente, s'engage à transmettre, en réponse à une demande dûment motivée par les autorités de contrôle, des informations pertinentes la quasi-machine. - ALLMATIC S.r.l., referencia para la documentación técnica pertinente, se compromete a facilitar, en respuesta a una solicitud debidamente motivada de las autoridades de control, información pertinente para la cuasi máquina.

Luogo e data - Place and date - Lieu et date - Lugar y fecha:
Borgo Valbelluna, 12/10/2022

PAOLO RAINERI - DIREZIONE

(Nome e posizione in stampatello)
(Name and title in block letters)

(Firma)
(Signature)

6-1626136 DOI TRAKTOR-I rev0 MULTI.docx